



XP/XT DC Utility Unit

Assembly guide for 50% & 100% utility units.



CONTENTS

1. Getting Started:	2
1.1. Product contents:	2
2. Utility assembly guide:	3
2.1. Tools required for assembly:	3
2.2. Step 1 – Base & rear panel assembly:	4
2.3. Step 2 – Side panel assembly:	4
2.4. Step 3 – Face plate assembly:	5
2.5. Step 4 – Face plate installation:	5
2.6. Step 5 (Optional) – Divider panel installation:	6
3. Notes:	7

SHOULD YOU HAVE ANY ENQUIRIES ABOUT THE FITMENT, FEEL FREE TO CONTACT US



1. Getting Started:

1.1. Product contents:

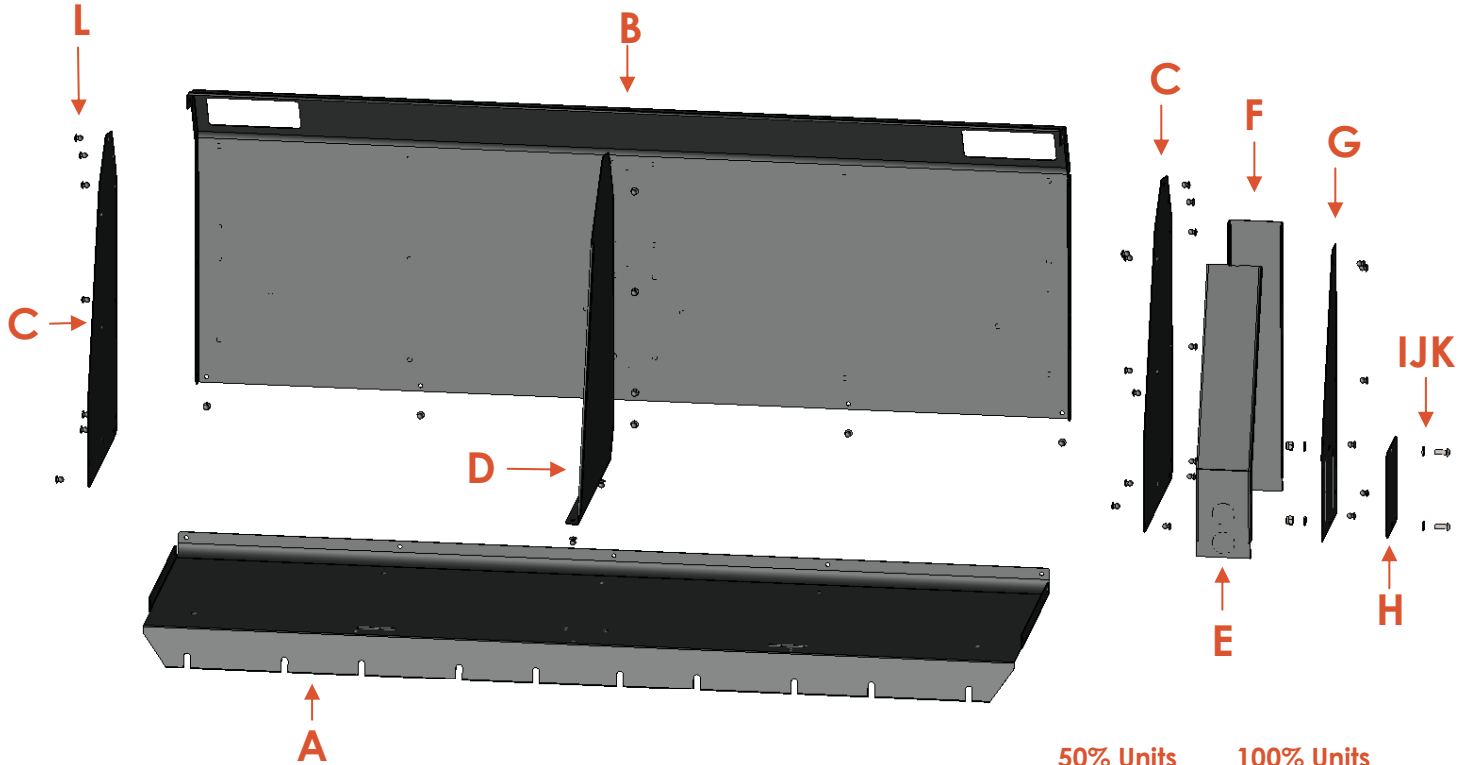

	<u>50% Units</u>	<u>100% Units</u>
A. Base panel	x 1	x 1
B. Rear panel	x 1	x 1
C. Side panels	x 2	x 2
D. Divider panel	x 0	x 1
E. Front face plate panel	x 1	x 1
F. Rear face plate panel	x 1	x 1
G. Side face plate panel	x 1	x 1
H. Face plate access panel	x 1	x 1
I. M6 x 20 Socket button head screw	x 2	x 2
J. M6 Flat washer	x 4	x 4
K. M6 Nyloc nut	x 2	x 2
L. Ø4.8 x 9.5 Black Pop rivet	x 30	x 36

SHOULD YOU HAVE ANY ENQUIRIES ABOUT THE FITMENT, FEEL FREE TO CONTACT US

2. Utility assembly guide:

Assembly duration approximately 25 minutes.



Be aware of the edges on all sheet metal components and take extra care during handling.

Although not included in the package, all pop rivets can be replaced with M5x12 screws, washers & nyloc nuts should you not possess a pop rivet gun.

PLEASE
NOTE...

Torque all M6 fasteners to 10.5Nm

The assembly of the utility unit will require 2 people for the ease of aligning all components.



The following vehicle illustration is used to define the “left-hand, right-hand and cab” side terminology used throughout the document.

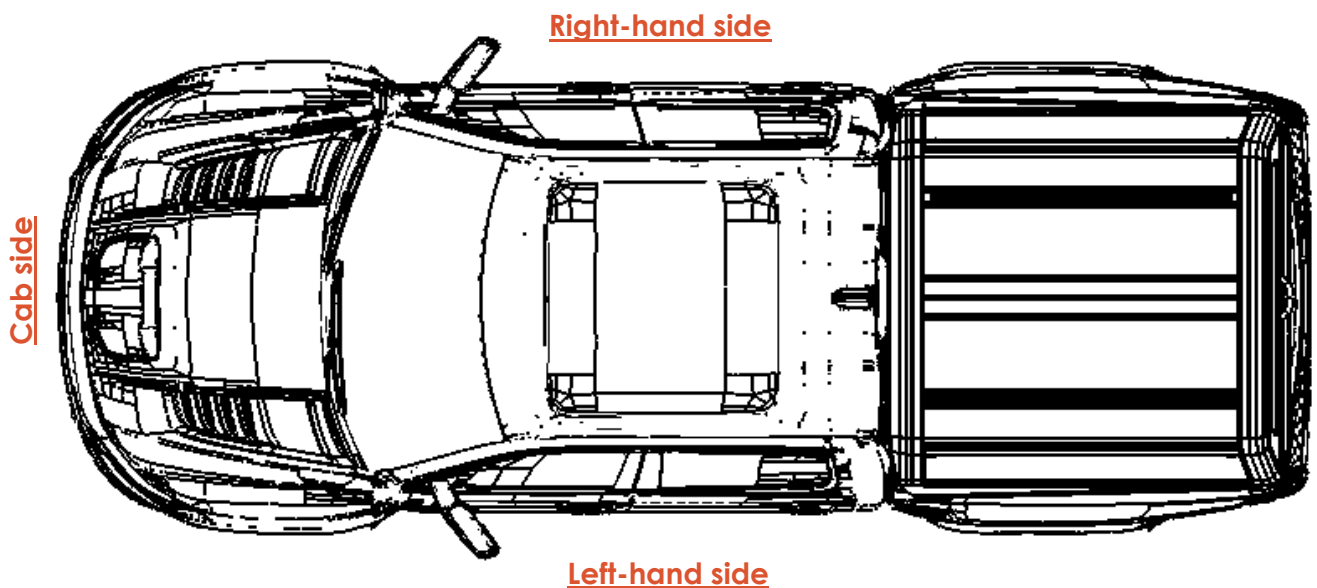

2.1. Tools required for assembly:

ALUMINIUM POP RIVET
TOOL



- 1 x Hand riveter gun suitable to pull \varnothing 4.8mm aluminium pop rivets.

ALLEN KEY WRENCH



- 1 x 4mm Allen Key

COMBINATION WRENCH



- 1 x 8mm Spanner
(Optional when replacing pop rivets with M5 fasteners)

SOCKET WRENCH



- 1 x 8mm Socket
(Optional when replacing pop rivets with M5 fasteners)

SHOULD YOU HAVE ANY ENQUIRIES ABOUT THE FITMENT, FEEL FREE TO CONTACT US

2.2. Step 1 – Base & rear panel assembly:

- Start by assembling the rear panel to the base panel. Align the rear panel central to the base panel, with the base panel placed on the inside of the rear panel. Fix the rear panel in place with Aluminium pop rivets, 4-off for 50% units, 5-off for 100% units.

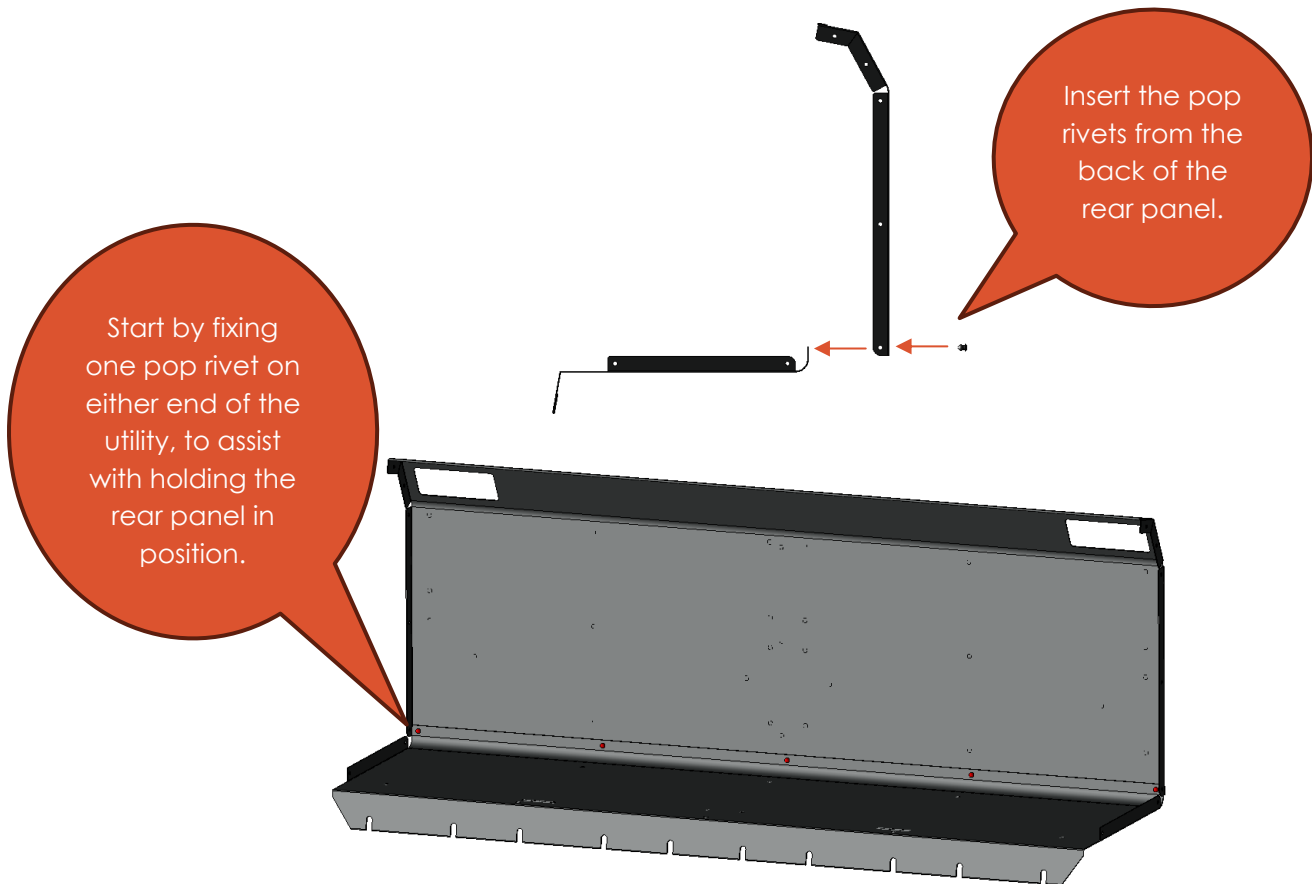

2.3. Step 2 – Side panel assembly:

- Install the side panels. The side panels are universal, thus no specific right-or-left hand.
- Place the side panels on the inside of the base-and-rear panel's flanges, align the holes all around the edges and insert 7 x pop rivets on each side panel from the outside inwards.

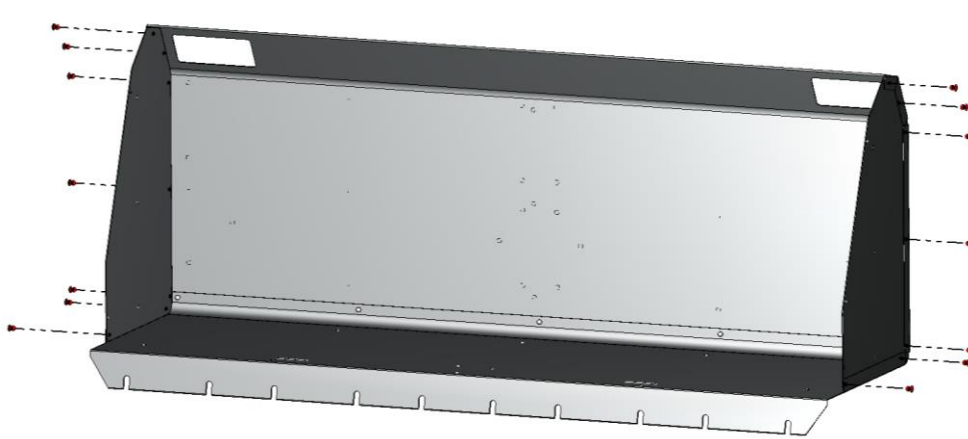

SHOULD YOU HAVE ANY ENQUIRIES ABOUT THE FITMENT, FEEL FREE TO CONTACT US

2.4. Step 3 – Face plate assembly:

- Assemble the face plate components.

The installation position of the face plate side panel determines on which side of the utility the face plate can be installed. Refer to the below steps when fitting the utility to the left-hand side of the vehicle or assemble opposite to the below when fitting the utility to the right-hand side of the vehicle.

PLEASE
NOTE...

- Align all the holes in the front & rear face plate with the side face plate, then insert a total of 6 x pop rivets as seen below (Fig.3,1):
- Install the face plate access panel by removing the dedicated pre-cut holes. Install the panel with 2 x M6 flat washers, 1 x M6 nylock nut & 1 x M6 x 20 socket button head screw.

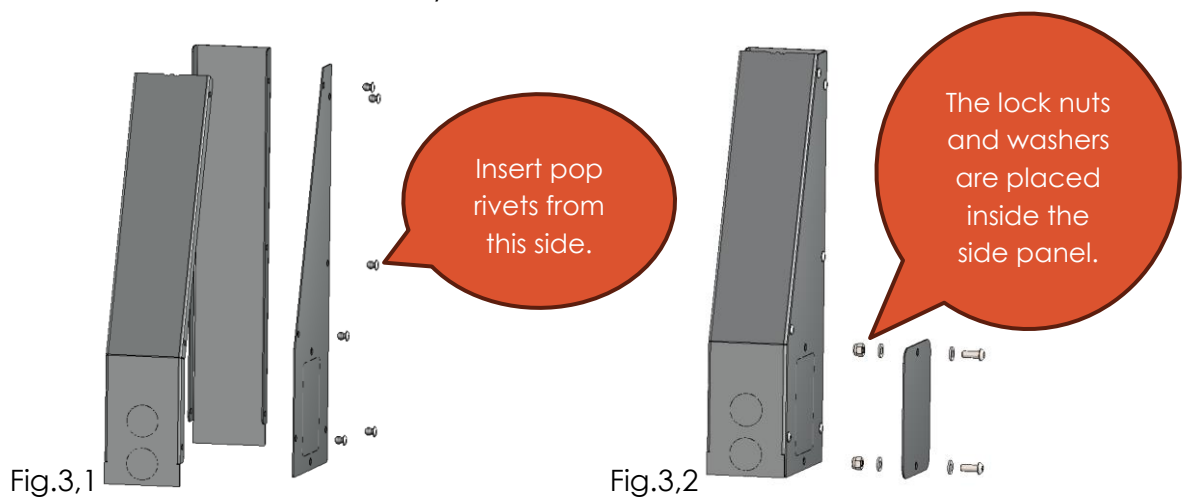

2.5. Step 4 – Face plate installation:

- Install the face plate to the utility.
- Install the face plate to the right-hand side of the utility when fitting the utility to the left-hand side of the vehicle (see Fig. 4,1). Install the face plate to the left-hand side of the utility when fitting the utility to the right-hand side of the vehicle (see Fig. 4,2).
- Install the face plate using 6 x pop rivets.

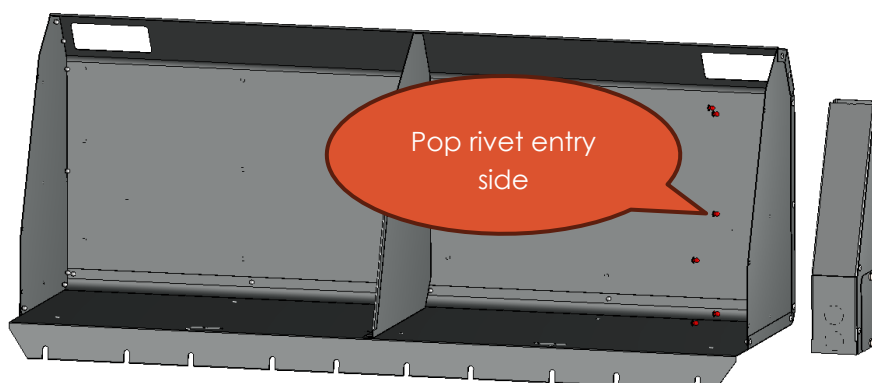

SHOULD YOU HAVE ANY ENQUIRIES ABOUT THE FITMENT, FEEL FREE TO CONTACT US

LEFT HAND SIDE FITMENT

Fig. 4,1

RIGHT HAND SIDE FITMENT

Fig. 4,2

2.6. Step 5 (Optional) – Divider panel installation:PLEASE
NOTE...

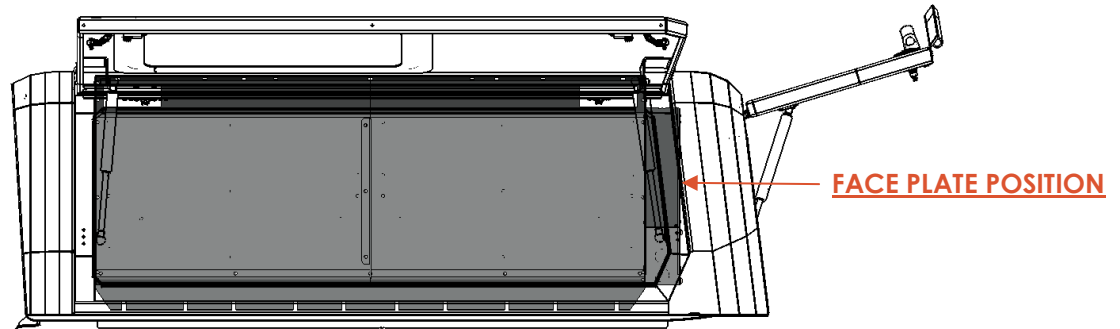
50% utility units are equipped to fit the divider panel in the center only.

- Choose a desired position to install the divider panel from the options below, identify the pre-cut hole positions for the desired position then remove the press-out pieces with an Allen key or screwdriver (see Fig.4,1).

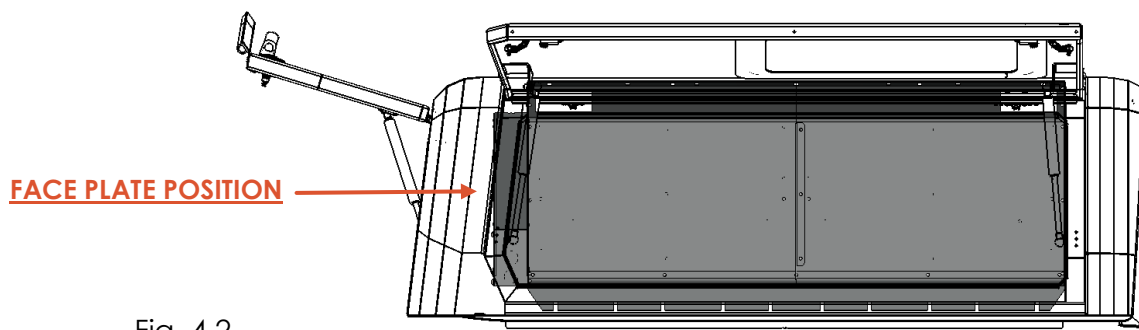
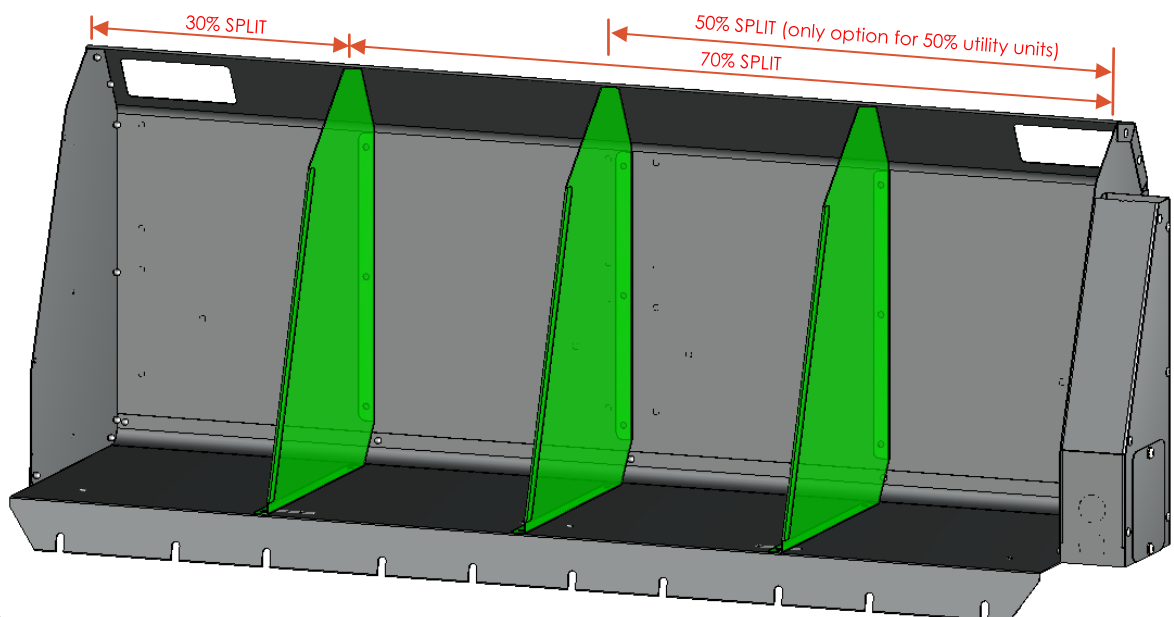
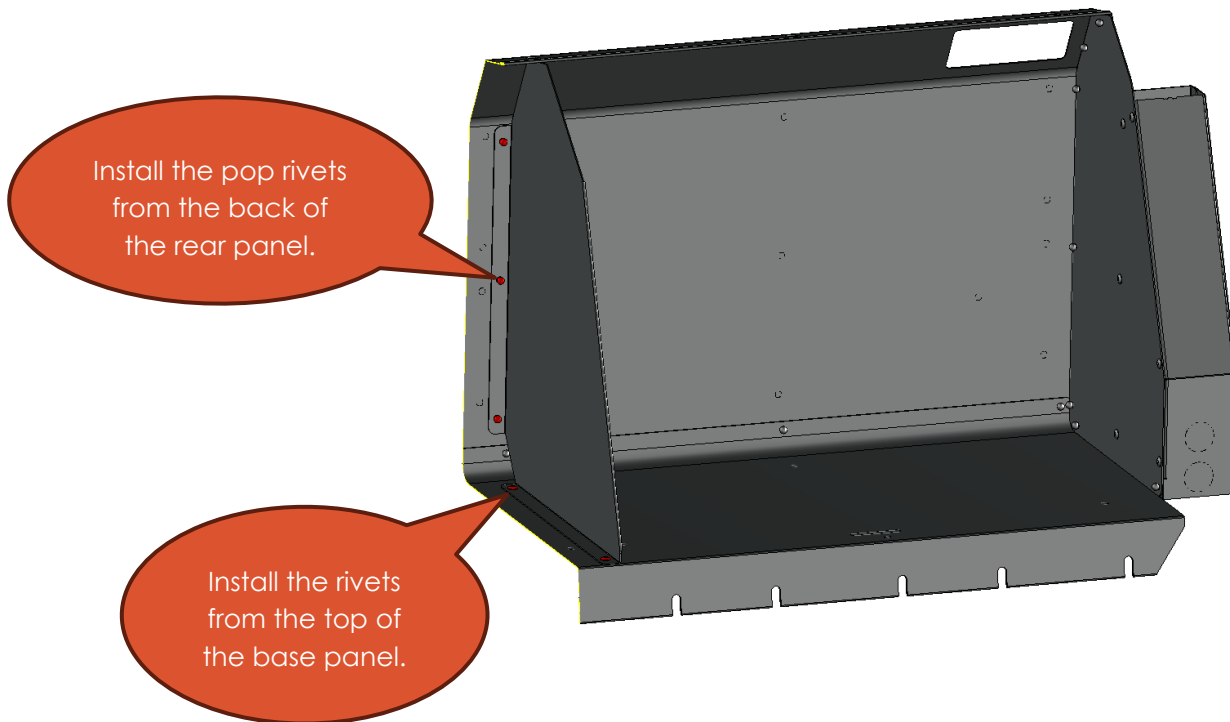

Fig. 4,1

SHOULD YOU HAVE ANY ENQUIRIES ABOUT THE FITMENT, FEEL FREE TO CONTACT US

- Place the divider panel, then install 3 x pop rivets through the rear panel and 2 x pop rivets through the base panel.



3. Notes:

- You have now successfully completed the assembly of your Rhinoman XP/XT utility unit.
- Confirm that all the fitment screws have been properly tightened one last time.
- Be sure to check at least bi-monthly that all the screws are still properly tightened.

SHOULD YOU HAVE ANY ENQUIRIES ABOUT THE FITMENT, FEEL FREE TO CONTACT US